



**MR. WATT**



# MINIATURE CIRCUIT BREAKERS (MCBs)



MR. WATT

## Technical Data

MCB	HDB9 18mm Circuit Breaker				
Electrical Features	Standard	IEC/EN 60898-1			
	Poles	1-4P			
	Rated Current $I_n$	1, 2, 4, 6, 10, 16, 20, 25, 32, 40, 50, 63 A			
	Rated Voltage $U_e$	1P:230/400V AC; 2P,3P,4P:400V AC			
	Insulation Voltage $U_i$	500V			
	Frequency	50/60Hz			
Breaking Capacity $I_{cn}$					
Electrical Features	Rate current(A)	Breaking capacity $I_{cn}$ (kA)	Type	Poles	Voltage (V)
	1-63	6	B,C,	1P 2P, 3P, 4P	230/400 400
	1-63	10	B,C,	1P 2P, 3P, 4P	230/400 400
Tripping Curve (see following tripping curve pictures)					
B Curve: the magnetic release operates between 3 and 5 $I_n$					
C Curve: the magnetic release operates between 5 and 10 $I_n$					
Other Features	Electrical Durability	10000 times			
	Mechanical Durability	20000 times			
	Protection Degree	IP20			
	Operating Temperature	-30°C ~ +70°C			

Trip free mechanism : MCB trips even if held in ON position.

Longer electrical life

Degree of Protection IP 20

Line Load clear indication

Contact indications window ( **Red = ON** & **GREEN = OFF** )

Dual Position Clamp

Operating Voltage 240V / 415V AC 50 Hz

ISI and CE marking, RoHs Compliant, Green Product

6A to 63A - B Curve | 0.5A to 63A - C Curve

0.5A to 63A - D Curve | 0.5A to 63A for DC Application

Single Pole (IP) | Single Pole & Neutral (IP+N)

Double Pole (2P) | Three Pole (3P)

Three Pole & Neutral (3P+N) | Four Pole (FP)

IS/IEC 60898-1 | IEC 60898-2 for DC Application

IEC 60947-2 for Industrial Application

## Tripping Curve

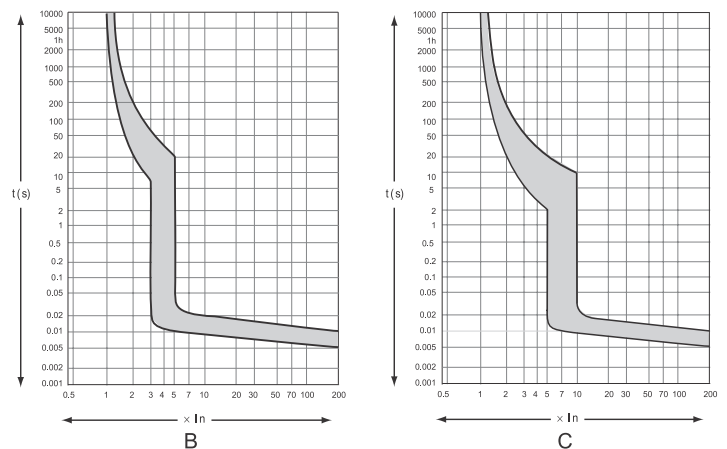



MR. WATT

# MINIATURE CIRCUIT BREAKERS (MCBs)



Single Pole MCB, C Curve, 6KA	
Current Rating in Amp.	Product Code
6	LSLE1C6
10	LSLE1C10
16	LSLE1C16
20	LSLE1C20
25	LSLE1C25
32	LSLE1C32
40	LSLE1C40
50	LSLE1C50
63	LSLE1C63



Single Pole Neutral MCB, C Curve, 6KA	
Current Rating in Amp.	Product Code
6	LSLE1NC6
10	LSLE1NC10
16	LSLE1NC16
20	LSLE1NC20
25	LSLE1NC25
32	LSLE1NC32
40	LSLE1NC40
50	LSLE1NC50
63	LSLE1NC63



Double Pole MCB, C Curve, 6KA	
Current Rating in Amp.	Product Code
6	LSLE2C6
10	LSLE2C10
16	LSLE2C16
20	LSLE2C20
25	LSLE2C25
32	LSLE2C32
40	LSLE2C40
50	LSLE2C50
63	LSLE2C63



Three Pole MCB, C Curve, 6KA	
Current Rating in Amp.	Product Code
6	LSLE3C6
10	LSLE3C10
16	LSLE3C16
20	LSLE3C20
25	LSLE3C25
32	LSLE3C32
40	LSLE3C40
50	LSLE3C50
63	LSLE3C63



Three Pole Neutral MCB, C Curve, 6KA	
Current Rating in Amp.	Product Code
6	LSLE3NC6
10	LSLE3NC10
16	LSLE3NC16
20	LSLE3NC20
25	LSLE3NC25
32	LSLE3NC32
40	LSLE3NC40
50	LSLE3NC50
63	LSLE3NC63



Four Pole MCB, C Curve, 6KA	
Current Rating in Amp.	Product Code
6	LSLE4C6
10	LSLE4C10
16	LSLE4C16
20	LSLE4C20
25	LSLE4C25
32	LSLE4C32
40	LSLE4C40
50	LSLE4C50
63	LSLE4C63

# MINIATURE CIRCUIT BREAKERS (MCBs)



MR. WATT



## Single Pole MCB, C CURVE, 10KA

Current Rating in Amp.	Product Code
6	LSLE1C6X
10	LSLE1C10X
16	LSLE1C16X
20	LSLE1C20X
25	LSLE1C25X
32	LSLE1C32X
40	LSLE1C40X
50	LSLE1C50X
63	LSLE1C63X

## Single Pole Neutral MCB, C CURVE, 10KA

Current Rating in Amp.	Product Code
6	LSLE1NC6X
10	LSLE1NC10X
16	LSLE1NC16X
20	LSLE1NC20X
25	LSLE1NC25X
32	LSLE1NC32X
40	LSLE1NC40X
50	LSLE1NC50X
63	LSLE1NC63X

## Double Pole MCB, C CURVE, 10KA

Current Rating in Amp.	Product Code
6	LSLE2C6X
10	LSLE2C10X
16	LSLE2C16X
20	LSLE2C20X
25	LSLE2C25X
32	LSLE2C32X
40	LSLE2C40X
50	LSLE2C50X
63	LSLE2C63X



## Three Pole MCB, C CURVE, 10KA

Current Rating in Amp.	Product Code
6	LSLE3C6X
10	LSLE3C10X
16	LSLE3C16X
20	LSLE3C20X
25	LSLE3C25X
32	LSLE3C32X
40	LSLE3C40X
50	LSLE3C50X
63	LSLE3C63X

## Three Pole Neutral MCB, C CURVE, 10KA

Current Rating in Amp.	Product Code
6	LSLE3NC6X
10	LSLE3NC10X
16	LSLE3NC16X
20	LSLE3NC20X
25	LSLE3NC25X
32	LSLE3NC32X
40	LSLE3NC40X
50	LSLE3NC50X
63	LSLE3NC63X

## Four Pole MCB, C CURVE, 10KA

Current Rating in Amp.	Product Code
6	LSLE4C6X
10	LSLE4C10X
16	LSLE4C16X
20	LSLE4C20X
25	LSLE4C25X
32	LSLE4C32X
40	LSLE4C40X
50	LSLE4C50X
63	LSLE4C63X





MR. WATT

# ISOLATORS SWITCHING DEVICE



Current rating in Amp.	DESCRIPTION	PRODUCT CODE
16	DOUBLE POLE MCB ISOLATOR	LSLE2ISO16
20	DOUBLE POLE MCB ISOLATOR	LSLE2ISO20
25	DOUBLE POLE MCB ISOLATOR	LSLE2ISO25
32	DOUBLE POLE MCB ISOLATOR	LSLE2ISO32
40	DOUBLE POLE MCB ISOLATOR	LSLE2ISO40
63	DOUBLE POLE MCB ISOLATOR	LSLE2ISO63
100	DOUBLE POLE MCB ISOLATOR	LSLE2ISO100



Current rating in Amp.	DESCRIPTION	PRODUCT CODE
25	FOUR POLE MCB ISOLATOR	LSLE4ISO25
32	FOUR POLE MCB ISOLATOR	LSLE4ISO32
40	FOUR POLE MCB ISOLATOR	LSLE4ISO40
63	FOUR POLE MCB ISOLATOR	LSLE4ISO63
80	FOUR POLE MCB ISOLATOR	LSLE4ISO80
100	FOUR POLE MCB ISOLATOR	LSLE4ISO100
120	FOUR POLE MCB ISOLATOR	LSLE4ISO125

# MCB CHANGE OVER



MR. WATT

Current rating in Amp.	DESCRIPTION	PRODUCT CODE
32A	DOUBLE POLE MCB CHANGOVER	LSLE2C032
40A	DOUBLE POLE MCB CHANGOVER	LSLE2C040
63A	DOUBLE POLE MCB CHANGOVER	LSLE2C063



Current rating in Amp.	DESCRIPTION	PRODUCT CODE
32A	THREE POLE MCB CHANGOVER	LSLE3C032
40A	THREE POLE MCB CHANGOVER	LSLE3C040
63A	THREE POLE MCB CHANGOVER	LSLE3C063



Current rating in Amp.	DESCRIPTION	PRODUCT CODE
32A	FOUR POLE MCB CHANGOVER	LSLE4C032
40A	FOUR POLE MCB CHANGOVER	LSLE4C040
63A	FOUR POLE MCB CHANGOVER	LSLE4C063
100 A	FOUR POLE MCB CHANGOVER	LSLE4C0100

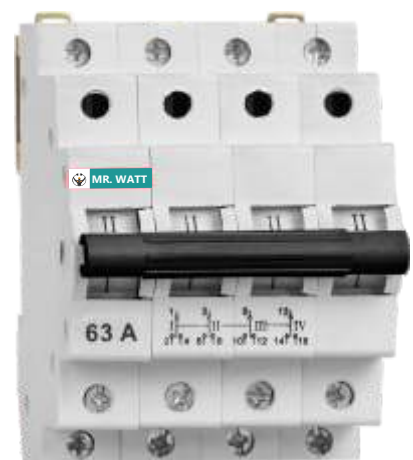



MR. WATT

# RESIDUAL CURRENT CIRCUIT BREAKERS (RCCBs)

A residual current circuit breaker (RCCB) is essential protection when it comes to protecting electrical circuits. It is a current sensing device that can mechanically live and trip the circuit

## Advantages

- Provides protection against ground faults in addition to any current leakage.
- Automatically switches off the circuit when the rated sensitivity is exceeded
- Offers the possibility of double termination for cable and conductor connections
- Provides protection against voltage fluctuations because it includes a filter device that protects against transient voltage levels.

## Current Sensitivity

A human is ready to withstand a 30mA electric shock. while up to 10mA can cause a tingling sensation, ten mA forward can lead to contraction, additionally resulting in a metabolic paralysis of about 30 mA. RCDs measure squarely thus designed to appear for small changes in residual current. In cases where protection from the fireplace is desired, RCCBs are also used to follow larger changes in the residual current up to 300mA.

## Limitations

- RCCB does not guarantee that it will work without common waveforms generated by masses. It is mainly due to the fact that RCCB is intended to work on traditional waveforms.
- There may be an unwanted shutdown of the RCCB. It is mainly due to the fact that, when there are rapid quadratic changes in the electrical load, there is often little current flowing to earth, especially in recent devices.
- RCCB does not protect against current overload. it is designed to shield only if the live current and neutral current square measure completely different. However, a current overload cannot be detected.
- RCCB does not protect against line neutral shocks. It is mainly because the current in them is balanced. the present is balanced if each terminals square measure command with it.
- Residual current circuit breaker does not protect against heating that occurs when conductors do not appear to be properly screwed into terminals.

## Classification

RCCB square size of 2 kinds; the two-pole RCD and the four-pole RCD.

2-pole RCD: This can be used in the case of a single-phase connection that only has a live and a neutral wire.

4-pole residual current circuit breaker: it can be used in the case of a three-phase connection.

Rating 10A to 100A

Sensitivity 30mA,100mA & 300mA

RCCB is thus extremely necessary in providing real-time protection for circuits. Especially in industries and high voltage installations, its importance cannot be undermined, as there are constant risks of shock and fatal accidents. At La Empresa India Pvt Ltd we offer RCCB, a cutting edge product suitable for industrial, residential and industrial applications. Mr. Watt RCCBs comply with IEC 61008 - one and are used for any electrical circuit management and isolation.

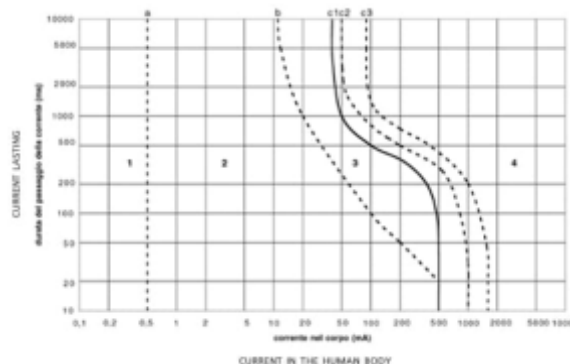
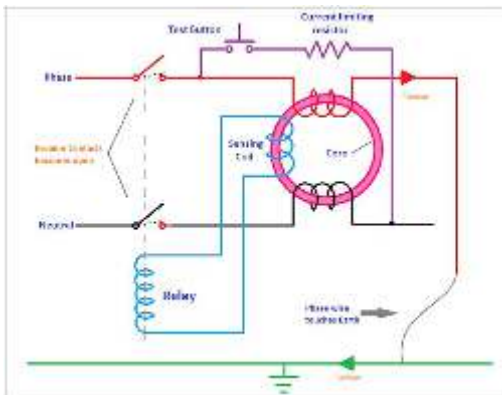

# RESIDUAL CURRENT CIRCUIT BREAKERS (RCCBs)



MR. WATT

## DOUBLE POLE RCCB

CURRENT RATING	SENSITIVITY	POLE	BREAKING CAP.	PRODUCT CODE
16A	30mA	2	10KA	LSLE2RCCB30M16
	100mA	2	10KA	LSLE2RCCB100M16
	300mA	2	10KA	LSLE2RCCB300M16
20A	30mA	2	10KA	LSLE2RCCB30M20
	100mA	2	10KA	LSLE2RCCB100M20
	300mA	2	10KA	LSLE2RCCB300M20
25A	30mA	2	10KA	LSLE2RCCB30M25
	100mA	2	10KA	LSLE2RCCB100M25
	300mA	2	10KA	LSLE2RCCB300M25
32A	30mA	2	10KA	LSLE2RCCB30M32
	100mA	2	10KA	LSLE2RCCB100M32
	300mA	2	10KA	LSLE2RCCB300M32
40A	30mA	2	10KA	LSLE2RCCB30M40
	100mA	2	10KA	LSLE2RCCB100M40
	300mA	2	10KA	LSLE2RCCB300M40
63A	30mA	2	10KA	LSLE2RCCB30M63
	100mA	2	10KA	LSLE2RCCB100M63
	300mA	2	10KA	LSLE2RCCB300M63



## FOUR POLE RCCB

CURRENT RATING	SENSITIVITY	POLE	BREAKING CAP.	PRODUCT CODE
16A	30mA	4	10KA	LSLE4RCCB30M16
	100mA	4	10KA	LSLE4RCCB100M16
	300mA	4	10KA	LSLE4RCCB300M16
20A	30mA	4	10KA	LSLE4RCCB30M20
	100mA	4	10KA	LSLE4RCCB100M20
	300mA	4	10KA	LSLE4RCCB300M20
25A	30mA	4	10KA	LSLE4RCCB30M25
	100mA	4	10KA	LSLE4RCCB100M25
	300mA	4	10KA	LSLE4RCCB300M25
32A	30mA	4	10KA	LSLE4RCCB30M32
	100mA	4	10KA	LSLE4RCCB100M32
	300mA	4	10KA	LSLE4RCCB300M32
40A	30mA	4	10KA	LSLE4RCCB30M40
	100mA	4	10KA	LSLE4RCCB100M40
	300mA	4	10KA	LSLE4RCCB300M40
63A	30mA	4	10KA	LSLE4RCCB30M63
	100mA	4	10KA	LSLE4RCCB100M63
	300mA	4	10KA	LSLE4RCCB300M63







**MR. WATT**

**SPN MCB DISTRIBUTION BOARD**

Way	Description	Type	DIMENSIONS IN MM (L X W X H)	Product Code
4	4 WAY SINGLE PHASE MCB DISTRIBUTION BOARD (DOUBLE DOOR)	STANDARD PLAIN	225 x 228 x 85	LSLESPNDBDD04
6	6 WAY SINGLE PHASE MCB DISTRIBUTION BOARD (DOUBLE DOOR)	STANDARD PLAIN	225 x 228 x 85	LSLESPNDBDD06
8	8 WAY SINGLE PHASE MCB DISTRIBUTION BOARD (DOUBLE DOOR)	STANDARD PLAIN	225 x 264 x 85	LSLESPNDBDD08
12	12 WAY SINGLE PHASE MCB DISTRIBUTION BOARD (DOUBLE DOOR)	STANDARD PLAIN		LSLESPNDBDD12



**SPN MCB DISTRIBUTION BOARD**

Way	Description	Type	DIMENSIONS IN MM (L X W X H)	Product Code
4	4 WAY SINGLE PHASE MCB DISTRIBUTION BOARD (DOUBLE DOOR)	STANDARD PRINTED	225 x 228 x 85	LSLESPNDBDDP04
6	6 WAY SINGLE PHASE MCB DISTRIBUTION BOARD (DOUBLE DOOR)	STANDARD PRINTED	225 x 228 x 85	LSLESPNDBDDP06
8	8 WAY SINGLE PHASE MCB DISTRIBUTION BOARD (DOUBLE DOOR)	STANDARD PRINTED	225 x 264 x 85	LSLESPNDBDDP08
12	12 WAY SINGLE PHASE MCB DISTRIBUTION BOARD (DOUBLE DOOR)	STANDARD PRINTED		LSLESPNDBDDP12



**SPN MCB DISTRIBUTION BOARD (POP UP TYPE)**

Way	Description	Type	DIMENSIONS IN MM (L X W X H)	Product Code
2+4	4 WAY SINGLE PHASE MCB DISTRIBUTION BOARD (DOUBLE DOOR)	POP UP TYPE	210 x 225 x 83	LSLESPNDBDD2+04
2+6	6 WAY SINGLE PHASE MCB DISTRIBUTION BOARD (DOUBLE DOOR)	POP UP TYPE	210 x 260 x 83	LSLESPNDBDD2+06
2+8	8 WAY SINGLE PHASE MCB DISTRIBUTION BOARD (DOUBLE DOOR)	POP UP TYPE	210 x 296 x 83	LSLESPNDBDD2+08
2+12	12 WAY SINGLE PHASE MCB DISTRIBUTION BOARD (DOUBLE DOOR)	POP UP TYPE	210 x 368 x 83	LSLESPNDBDD2+12
2+14	14 WAY SINGLE PHASE MCB DISTRIBUTION BOARD (DOUBLE DOOR)	POP UP TYPE	210 x 404 x 83	LSLESPNDBDD2+14





MR. WATT

#### TPN MCB DISTRIBUTION BOARD (HORIZONTAL) WITH 100A FP ISOLATOR

WAY	DESCRIPTION	DOOR	DIMENSION IN MM	PRODUCT CODE
4 WAY	4 WAY THREE PHASE MCB DISTRIBUTION BOARD (TPN HORIZONTAL DB)	DOUBLE DOOR	470 X 404 110	LSLETPNDBHDD04LE4ISO100
6 WAY	6 WAY THREE PHASE MCB DISTRIBUTION BOARD (TPN HORIZONTAL DB)	DOUBLE DOOR	470 X 404 110	LSLETPNDBHDD06LE4ISO100
8 WAY	8 WAY THREE PHASE MCB DISTRIBUTION BOARD (TPN HORIZONTAL DB)	DOUBLE DOOR	578 X 404 110	LSLETPNDBHDD08LE4ISO100
12 WAY	12 WAY THREE PHASE MCB DISTRIBUTION BOARD (TPN HORIZONTAL DB)	DOUBLE DOOR		LSLETPNDBHDD12LE4ISO100



#### TPN MCB DISTRIBUTION BOARD (VERTICAL) WITH 100A FP ISOLATOR

WAY	DESCRIPTION	DOOR	DIMENSION IN MM	PRODUCT CODE
4 WAY	4 WAY THREE PHASE MCB DISTRIBUTION BOARD (TPN VERTICAL DB)	DOUBLE DOOR	470 X 404 110	LSLETPNDBVDD04LE4ISO100
6 WAY	6 WAY THREE PHASE MCB DISTRIBUTION BOARD (TPN VERTICAL DB)	DOUBLE DOOR	470 X 404 110	LSLETPNDBVDD06LE4ISO100
8 WAY	8 WAY THREE PHASE MCB DISTRIBUTION BOARD (TPN VERTICAL DB)	DOUBLE DOOR	578 X 404 110	LSLETPNDBVDD08LE4ISO100
12 WAY	12 WAY THREE PHASE MCB DISTRIBUTION BOARD (TPN VERTICAL DB)	DOUBLE DOOR		LSLETPNDBVDD12LE4ISO100





MR. WATT

## ON LOAD CHANGEOVER SWITCHES COMPACT VERSION

### RANGE & FRAME SIZE

Current range 40 A to 3150 A in nine frame sizes in Four Pole in Open Execution

SIZE 1	40A, 63A.
SIZE 2	80A, 100A.
SIZE 3	125A.
SIZE 4	160A, 200A.
SIZE 5	250A, 320A.
SIZE 6	400A, 630A.
SIZE 7	800A.
SIZE 8	1000A, 1250A, 1600A.
SIZE 9	2000A, 2500A, 3150A.

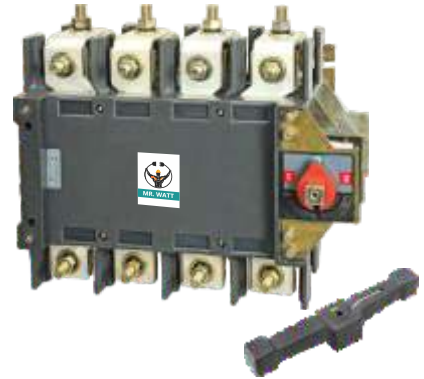

400 Amps. Four Pole 415 V  
(Open Execution)

### SPECIFICATIONS

Rated Operating Voltage (V)	415
Rated Insulation Voltage (Ui)	1000 V
Rated Frequency (Hz)	50
Utilization Category	AC 23 A (63A-320A), AC 22 A (400A-3150A)
Rated impulse withstand Voltage (Uimp)	10 kV

### SALIENT FEATURES

- While breaking the circuit, guaranteed sufficient air sectioning clearance .
- Utilization category - AC 23A/AC22A.
- Flexibility in mounting - horizontal or vertical.
- Strong endurance and resistance to heat ( Tropicalised ).
- Flag indicator for two stable positions ( I-O ) & possible switching on or off, on load, thereby fulfilling the roll of switching device.
- All current carrying parts are of special grade E.T.P. Copper and with silver plated.
- Knife type contact system with self wipe feature allows cleaning of contact during each operation, calling for lesser maintenance and higher life.
- Torque required for switch operation is low.
- Easy add on auxiliary contact up to 1 NO & 1 NC for signalisation & interlocking.
- Bolt locking system for easy installation.
- The moulded body's raw material is Glass Fiber reinforced polyester (SMC) which has high mechanical and dielectric strength.
- Protection against over current and short circuit fault of high rupturing capacity upto 80 kA.
- Compact and standardized sizes for range 63A- 3150 A - ideal for switch board manufacturers.
- Phase barriers between each phase terminal.

# ON LOAD CHANGEOVER SWITCHES



MR. WATT

## CONSTRUCTION

A complete range of On load changeover switches have been designed and developed indigenously to meet various need of distribution circuits. They provide breaking or switching off on load and safety isolation.

The switching mechanism is quick make, quick break type independent of the speed of the operation, There are four breaks per pole thereby resulting into faster quenching of arc, The load and line can be connected on either side by virtue of isolation on both the sides, The entire switching mechanism along with the fixed and moving contact assembly are housed in a polyester reinforced, moulded frame/cover, having high dielectric strength & thermal withstand capacity.



## CONTACT MECHANISM

The contact mechanism is knife blade type with self cleaning action during operation, The fixed contact terminals in each phase have separate main and arcing contacts. The moving contact assembly has a four set of contact on moving carrier and the each set of contacts. Loaded with bouncing type strip springs which assist in the true movement during the making and breaking.

The moving contact mates with the fixed contact by a slide movement of the moving contact assembly. The contact is first made with the arcing contact and thereafter with the main contact, During breaking, the arc formation is across the arcing contacts thereby protecting the main contacts which results into enhanced life of the switch, The arc is effectively confined & quenched by the arc barrier in each phase.

The switches can be mounted inside a panel either in horizontal or vertical mode without any effect on the performance.



## OPERATING MECHANISM

The operating mechanism consists of single/double side front operated handle which drives the spring assisted toggle mechanism, in turn operating the switch, There is a distinct indication of the position of the switch by way of side mounted flag indicator carrying the rotation O/I in addition to position indication provided on front of switch, i.e. on the operating shaft.

In position 'I', supply I (Main) is connected to the load, supply II is off,

In position 'O', supply I & II are both disconnected from the load,

In position 'II', supply II (Standby) is connected to the load, supply I is off.

Hence in none of the cases, supply I & II are connected simultaneously,







**MR. WATT**

# ON LOAD CHANGEOVER SWITCHES

## TECHNICAL DATA FOR ON LOAD CHANGEOVER SWITCHES

CONFORMS TO IEC 60947, IS/IEC 60947-3

### ELECTRICAL & MECHANICAL CHARACTERISTICS

Thermal Current at 40° C, $I_{th}$	40A	63A	80A	
Nos. of Poles	4	4	4	
Insulation Voltage $U_i$ (V)	1000	1000	1000	
Rated operational voltage, $U_e$ (V) AC	415	415	415	
Dielectric strength (V) 50 Hz 60 Sec.	5000	5000	5000	
Impulse Voltage (kV) (Uimp)	10	10	10	
<b>Rated Operational Current <math>I_e</math> (A)</b>				
415V AC : AC 23A / AC 23B	63/63	63/63	63/63	
500V AC: AC 23A/ AC 23B	55/55	55/55	55/55	
Rated making capacity Amp, 415V AC 23A, p.f.-0.35	630	630	630	
Rated breaking capacity Amp, 415V AC23A, p.f. -0.35	504	504	504	
<b>Rated Operational Power</b>				
Rated Motor Power 415 V, 3 O (kW)	22	22	22	
Rated Capacitor Power 415V (kVAR)	20	20	20	
<b>Fuse protected short circuit withstand</b>				
Rated max. Current of gG fuses (A)	63	63	63	
Rated conditional short circuit current (kArms)	80	80	80	
Max. Allowed cut off current (kApeak)	12	12	12	
Rated short time withstand current (1Sec.) (kArms)	7.5	7.5	7.5	
<b>Withstand</b>				
Mechanical Endurance	10000	10000	10000	
Electrical Endurance	8500	8500	8500	
No. of ON LOAD operating cycle Pf = 0.65 AC 23 A 415 V	1500	1500	1500	
Temperature withstand range (ambient) (°C)	-5 to 50	-5 to 50	-5 to 50	
Operating Force (Nm)	9.00	9.00	9.00	
<b>Terminal connection</b>				
Al. Cable cross section (Sq.mm)	25	25	25	
Maximum bar width (Cu) (Sq.mm)	16	16	16	
<b>Weight</b>				
Open Execution	(Kg)	2.25	2.5	2.75
In Thick Sheet Enclosure	(Kg)	6.5	8.1	8.5

Product improvement is a continuous process. Above technical data is subject to be changed at any time owing to latest technological development.

# ON LOAD CHANGEOVER SWITCHES



MR. WATT

100A	125A	160A	200A	250A	320A
4	4	4	4	4	4
1000	1000	1000	1000	1000	1000
415	415	415	415	415	415
5000	5000	5000	6000	6000	6000
10	10	10	10	10	10
100/100	125/125	125/125	200/200	250/250	320/320
80/80	105/105	105/105	165/200	210/250	265/320
1000	1250	1250	2000	2500	3200
800	1000	1000	1600	2000	2560
33	55	55	90	132	160
30	50	50	80	100	125
100	125	125	200	250	320
80	80	80	80	80	80
12	20	20	30	45	45
7.5	7.5	7.5	10	10	15
10000	8000	8000	8000	8000	8000
8500	7000	7000	7000	7000	7000
1500	1000	1000	1000	1000	1000
-5 to 50	-5 to 50	-5 to 50	-5 to 50	-5 to 50	-5 to 50
9.00	10.00	10.00	11.00	12.00	12.00
35	70	70	150	240	240
16	50	50	95	150	185
2.9	5.7	5.95	6	11.3	10.2
8.6	11.85	12	12	20.7	20.9

Product improvement is a continuous process. Above technical data is subject to be changed at any time owing to latest technological development.



**MR. WATT**

# ON LOAD CHANGEOVER SWITCHES

## TECHNICAL DATA FOR ON LOAD CHANGEOVER SWITCHES

CONFORMS TO IEC 60947, IS/IEC 60947-3

### ELECTRICAL & MECHANICAL CHARACTERISTICS

Thermal Current at 40° C, I <sub>th</sub>	400A	630A	800A
Nos. of Poles	4	4	4
Insulation Voltage U <sub>i</sub> (V)	1000	1000	1000
Rated operational voltage, U <sub>e</sub> (V) AC	415	415	415
Dielectric strength (V) 50 Hz 60 Sec.	8000	8000	10000
Impulse Voltage (kV) (U <sub>imp</sub> )	12	12	12
<b>Rated Operational Current I<sub>e</sub> (A)</b>			
415V AC : AC 23A / AC 23B	400/400	630/630	800/800
500V AC: AC 23A/ AC 23B	335/400	525/630	665/800
Rated making capacity Amp, 415V AC 23A, p.f.-0.35	4000	6300	8000
Rated breaking capacity Amp, 415V AC23A, p.f. -0.35	3200	5040	6400
<b>Rated Operational Power</b>			
Rated Motor Power 415 V, 3 Ø (kW)	220	315	450
Rated Capacitor Power 415V (kVAR)	160	250	300
<b>Fuse protected short circuit withstand</b>			
Rated max. Current of gG fuses (A)	400	630	630/800
Rated conditional short circuit current (kArms)	80	80	80
Max. Allowed cut off current (kA <sub>peak</sub> )	45	100	100
Rated short time withstand current (1Sec.) (kArms)	80	80	80
<b>Withstand</b>			
Mechanical Endurance	5000	4000	4000
Electrical Endurance	4000	3000	3000
No. of ON LOAD operating cycle Pf = 0.65 AC 23 A 415 V	1000	1000	1000
Temperature withstand range (ambient) (°C)	-5 to 50	-5 to 50	-5 to 50
Operating Force (Nm)	20.00	20.00	40.00
<b>Terminal connection</b>			
Al. Cable cross section (Sq.mm)	300	2x300	3x300
Maximum bar width (Cu) (Sq. mm)	240	240	240
<b>Weight</b>			
Open Execution (Kg)	21.6	28.75	36.6
In Thick Sheet Enclosure (Kg)	47.5	49.85	62.5

Product improvement is a continuous process. Above technical data is subject to be changed at any time owing to latest technological development.

# ON LOAD CHANGEOVER SWITCHES



MR. WATT

1000A	1250A	1600A	2000A	2500A	3150A
4	4	4	4	4	4
1000	1000	1000	1000	1000	1000
415	415	415	415	415	415
10000	10000	10000	10000	10000	10000
12	12	12	12	12	12
1000/1000	1200/1250	1600/1600	1600/2000	1600/2000	1600/2000
840/1000	1040/1250	1350/1600	1350/1600	1350/1600	1350/1600
10000	12500	16000	20000	20000	20000
8000	10000	12800	16000	16000	16000
560	600	650	800	950	1100
400	450	500	600	700	825
1000	1250	2x800	2x1000	2x1250	2x1250
80	80	80	80	80	80
110	110	110	110	110	110
80	80	80	80	80	80
4000	4000	4000	4000	4000	2000
3000	3000	3000	3000	3000	1500
1000	1000	1000	1000	1000	500
-5 to 50	-5 to 50	-5 to 50	-5 to 50	-5 to 50	-5 to 50
42.00	45.00	50.00	60.00	70.00	70.00
4x300	50x8x4	100x10x3	100x10x3	100x10x4	150x10x4
240	100x5x2	100x5x3	125	100x5x4	100x10x3
46	49	52	120	130	140
82.7	85.5	90.1	162	176	188

Product improvement is a continuous process. Above technical data is subject to be changed at any time owing to latest technological development.





MR. WATT

# ON LOAD CHANGEOVER SWITCHES

## INSTALLATION & FIXING OF ACCESSORIES

32 A - 100 A

USE SCREW FOR MOUNTING  
HANDLES ON ALL MODELS

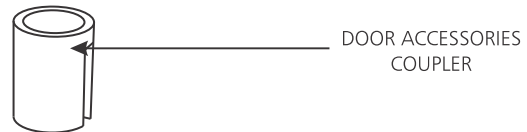
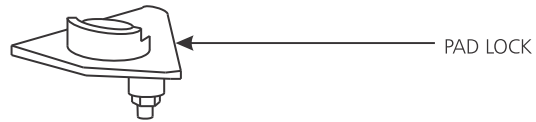
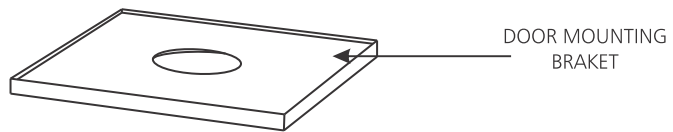
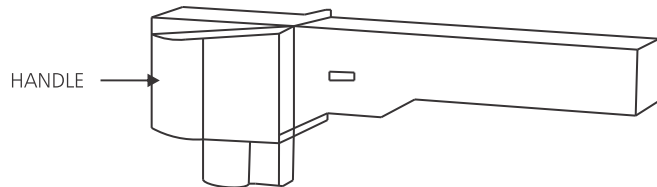

### INSTALLATION INSTRUCTIONS

- \* Use Copper lugs for proper termination.
- \* Use of bolt lock & washer during connections.
- \* NO / NC switches for indication of contacts.
- \* Operation can lock with handle lock.
- \* Slot on Mounting leg for mounting.

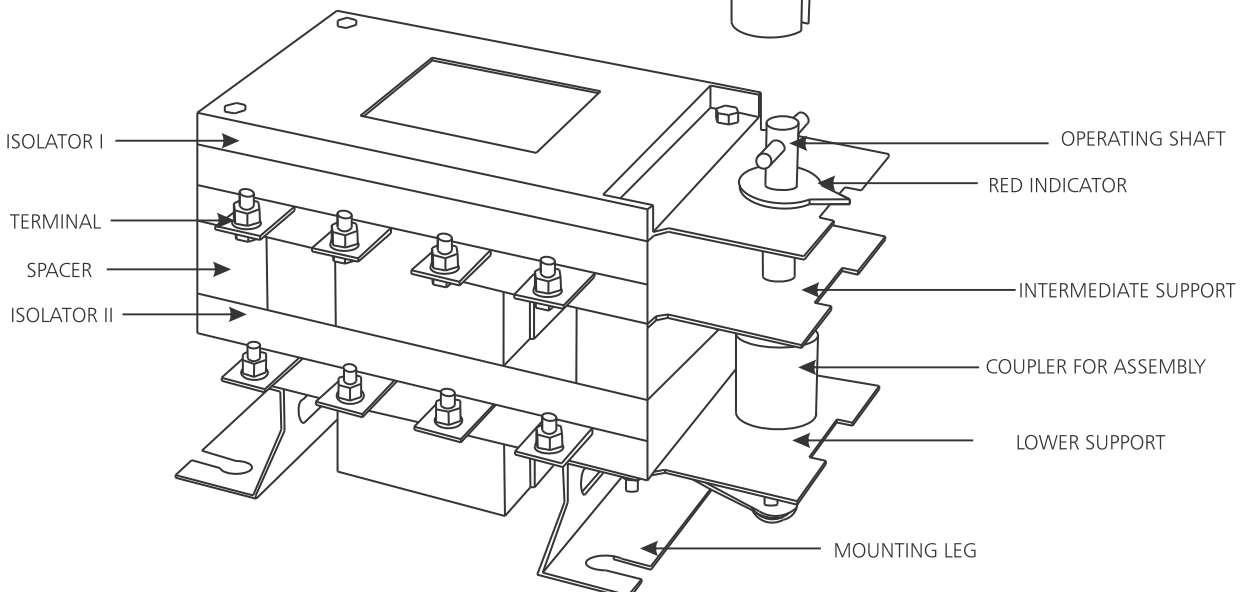



## INSTALLATION & FIXING OF ACCESSORIES

125 A - 3150 A

USE SCREW FOR MOUNTING HANDLES ON ALL MODELS

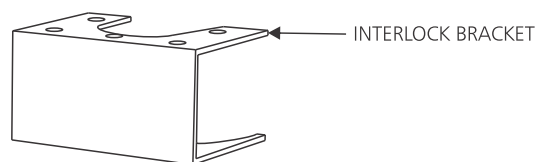
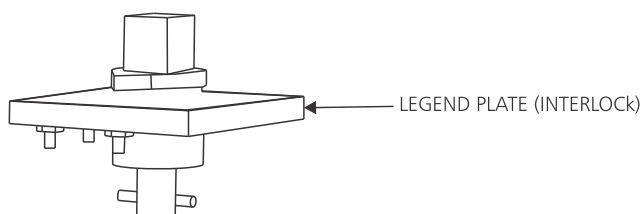
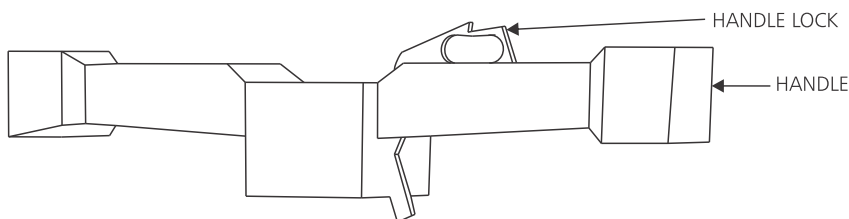

## INSTALLATION INSTRUCTIONS

- \* Use Copper lugs for proper termination.
- \* Use of bolt lock & washer during connections.
- \* NO/NC switches for indication of contacts.
- \* Operation can lock with handle lock.
- \* Slot on Mounting leg for mounting.

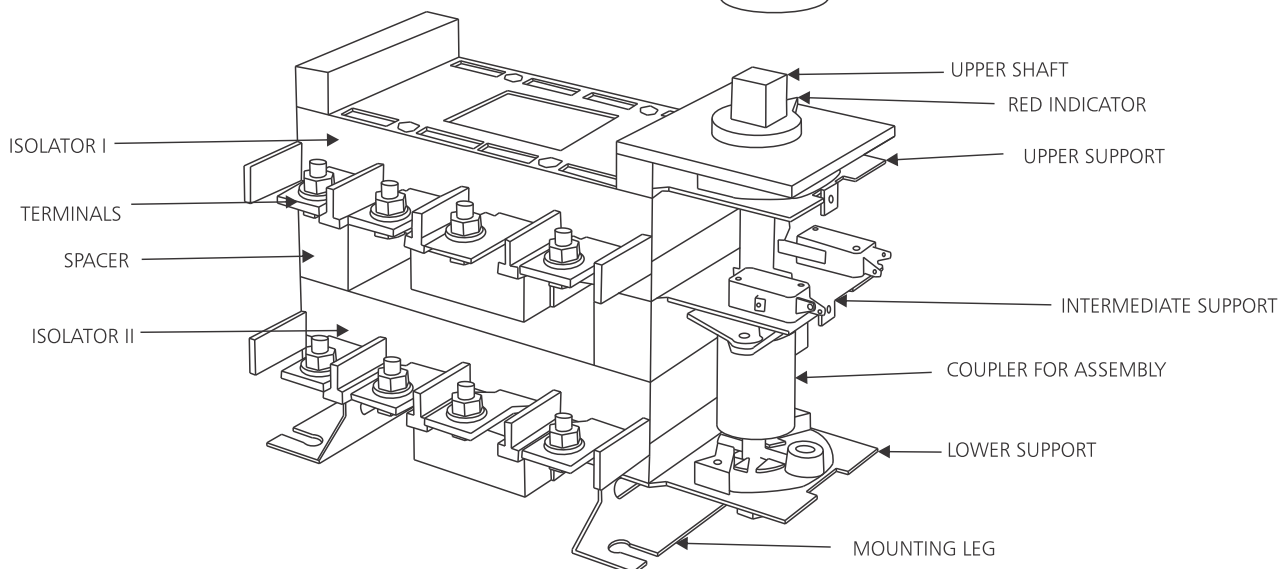



MR. WATT

# ON LOAD CHANGEOVER SWITCHES

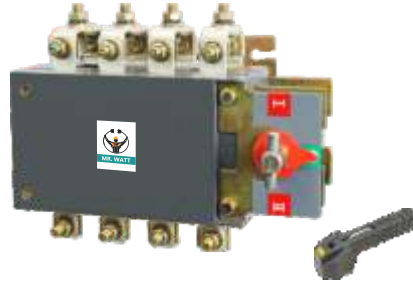

Current Rating (A)	Open Execution Cat. No.
40A	COC40
63A	COC63

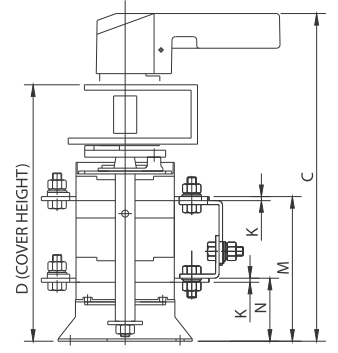
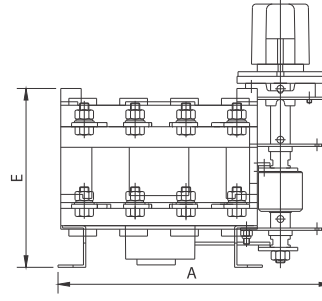
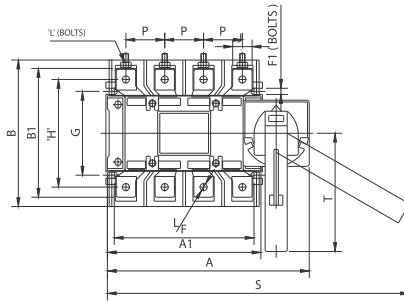

ALL DIMENSIONS ARE IN MM.

AMPS	FRAME	OVER ALL DIMENSIONS				FEET HOLE			TERMINAL DIMENSIONS										
		TOTAL LENGTH	TOTAL WIDTH	TOTAL HEIGHT	COVER HEIGHT	A1	B1	E	F	G	H	J	K	L	M	N	P	S	T
40A	1	190	130	200	150	145	130	113	125	95	115	16	2.5	6	92	42	32	270	65
63A	1	190	130	200	150	145	130	113	125	95	115	16	2.5	6	92	42	32	270	65

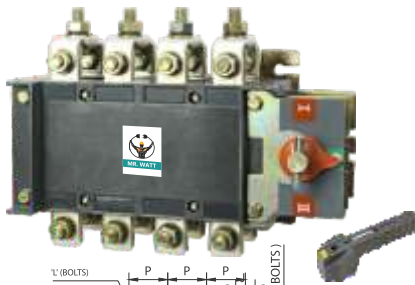

Current Rating (A)	Open Execution Cat. No.
80A	COC80
100A	COC100

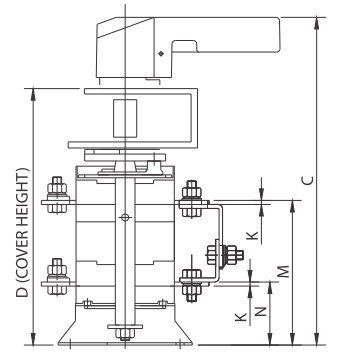
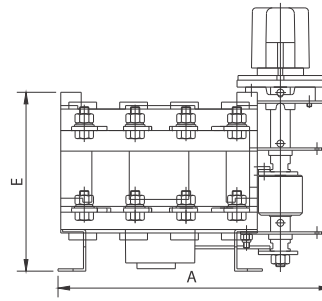
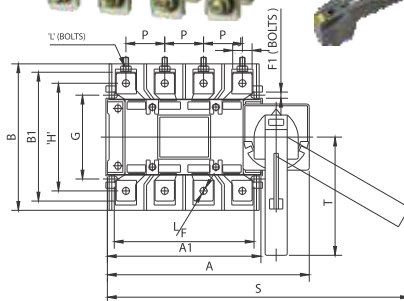

ALL DIMENSIONS ARE IN MM.

AMPS	FRAME	OVER ALL DIMENSIONS				FEET HOLE			TERMINAL DIMENSIONS										
		TOTAL LENGTH	TOTAL WIDTH	TOTAL HEIGHT	COVER HEIGHT	A1	B1	E	F	G	H	J	K	L	M	N	P	S	T
80A	1	215	135	200	150	170	135	115	145	95	115	18.5	3.0	8	92	42	36	290	105
100A	1	215	135	200	150	170	135	115	145	95	115	18.5	3.0	8	92	42	36	290	105

Product improvement is a continuous process. Above technical data is subject to be changed at any time owing to latest technological development.

# ON LOAD CHANGEOVER SWITCHES



MR. WATT

Current Rating (A)	Open Execution Cat. No.
125A	COC125
160A	COC160
200A	COC200

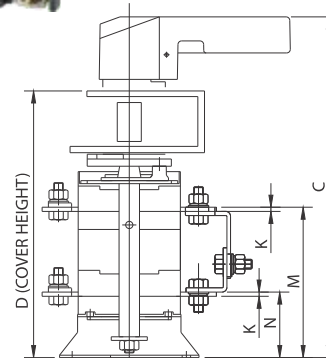
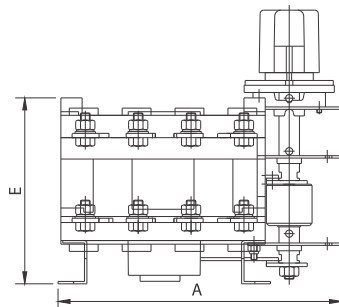
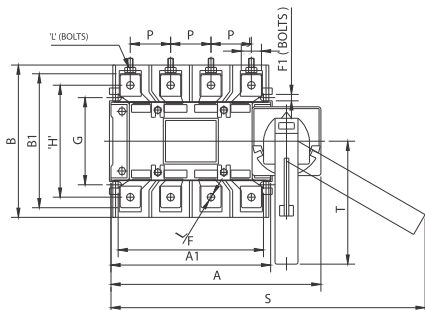

ALL DIMENSIONS ARE IN MM.

AMPS	FRAME	OVER ALL DIMENSIONS				FEET HOLE					TERMINAL DIMENSIONS								
		TOTAL LENGTH	TOTAL WIDTH	TOTAL HEIGHT	COVER HEIGHT	A1	B1	E	F	G	H	J	K	L	M	N	P	S	T
125A	1	225	150	320	245	170	150	150	150	95	125	22	3.5	8	120	53	44	315	135
160A	1	225	150	335	265	170	150	165	150	95	125	22	4.0	8	130	56	44	315	135
200A	1	225	150	335	265	170	150	165	150	95	125	22	5.0	8	130	56	44	315	135

Current Rating (A)	Open Execution Cat. No.
250A	COC250
320A	COC320

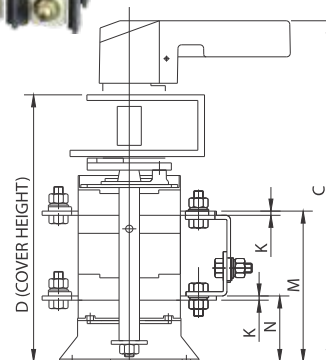
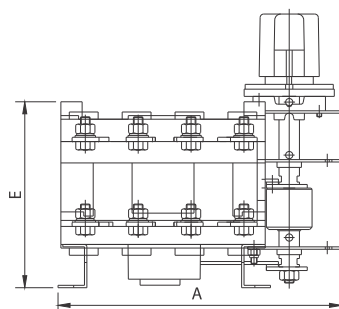
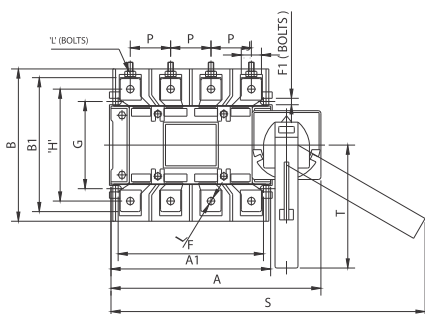
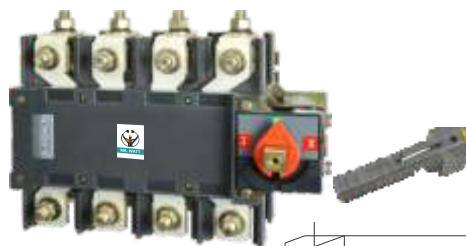

ALL DIMENSIONS ARE IN MM.

AMPS	FRAME	OVER ALL DIMENSIONS				FEET HOLE					TERMINAL DIMENSIONS								
		TOTAL LENGTH	TOTAL WIDTH	TOTAL HEIGHT	COVER HEIGHT	A1	B1	E	F	G	H	J	K	L	M	N	P	S	T
250A	1	300	200	340	265	245	200	175	205	111	155	32	5.0	12	142	64	62	420	160
320A	1	300	200	340	265	245	200	175	205	111	155	32	5.6	12	142	64	62	420	160

Product improvement is a continuous process. Above technical data is subject to be changed at any time owing to latest technological development.



MR. WATT

# ON LOAD CHANGEOVER SWITCHES

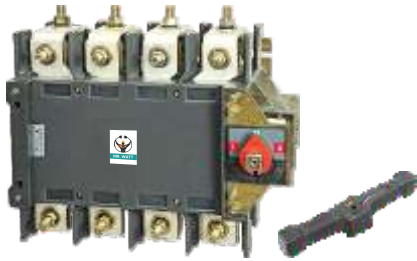

Current Rating (A)	Open Execution Cat. No.
400A	COC400
630A	COC630

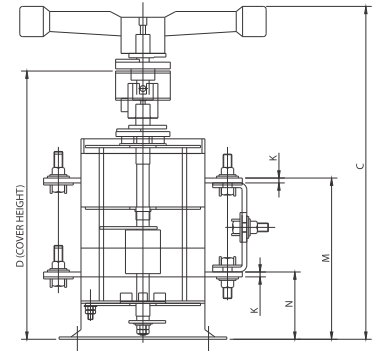
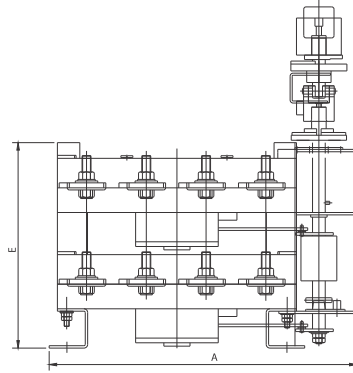
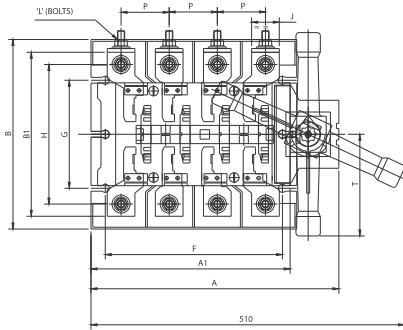

ALL DIMENSIONS ARE IN MM.

AMPS FRAME	OVER ALL DIMENSIONS	FEET HOLE										TERMINAL DIMENSIONS							
		TOTAL LENGTH	TOTAL WIDTH	TOTAL HEIGHT	COVER HEIGHT	A1	B1	E	F	G	H	J	K	L	M	N	P	S	T
400A	1	375	290	400	335	320	270	240	290	180	230	46	6.0	12	198	88	80	480	170
630A	1	375	290	400	335	320	270	240	290	180	230	52	7.0	16	198	88	80	480	170

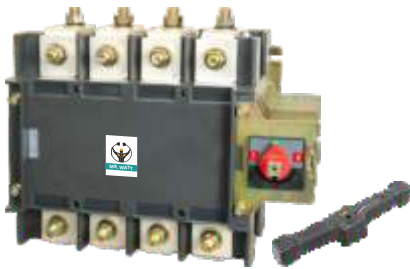

Current Rating (A)	Open Execution Cat. No.
800A	COC800

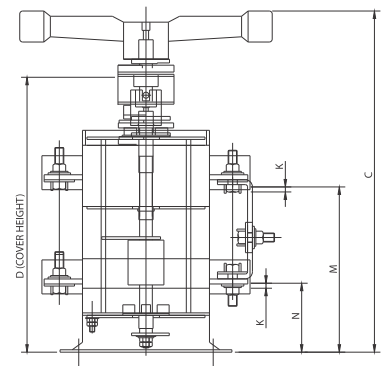
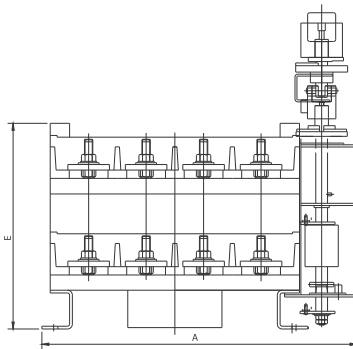
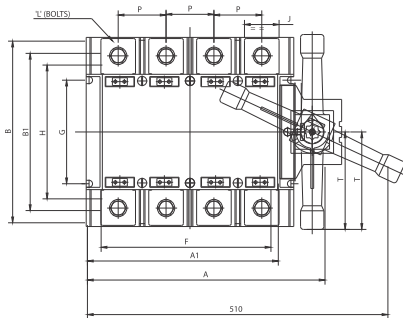

ALL DIMENSIONS ARE IN MM.

AMPS FRAME	OVER ALL DIMENSIONS	FEET HOLE										TERMINAL DIMENSIONS							
		TOTAL LENGTH	TOTAL WIDTH	TOTAL HEIGHT	COVER HEIGHT	A1	B1	E	F	G	H	J	K	L	M	N	P	S	T
800A	1	445	330	460	385	360	320	300	360	225	270	60	7.0	16	235	100	80	560	170

Product improvement is a continuous process. Above technical data is subject to be changed at any time owing to latest technological development.

# ON LOAD CHANGEOVER SWITCHES



MR. WATT

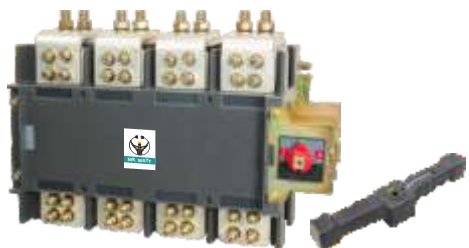

Current Rating (A)	Open Execution Cat. No.
1000A	COC1000
1250A	COC1250
1600A	COC1600

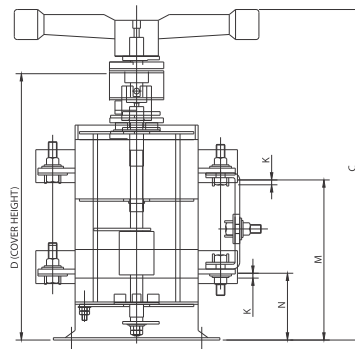
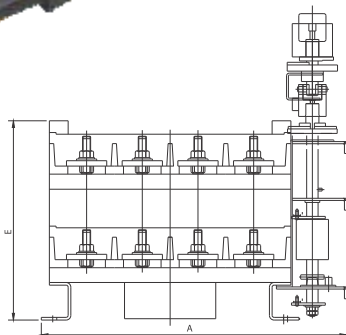
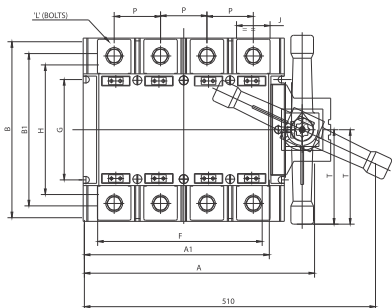

ALL DIMENSIONS ARE IN MM.

AMPS FRAME		OVER ALL DIMENSIONS				FEET HOLE					TERMINAL DIMENSIONS								
		TOTAL LENGTH	TOTAL WIDTH	TOTAL HEIGHT	COVER HEIGHT	A1	B1	E	F	G	H	TERMINAL WIDTH	TERMINAL THICKNESS	TERMINAL BOLTS	M	N	P	S	T
1000A	1	595	340	460	390	510	340	300	510	225	280	70	7.0	10	245	110	120	630	170
1250A	1	595	340	460	390	510	340	300	510	225	280	70	9.0	10	245	110	120	630	170
1600A	1	595	340	460	390	510	340	300	510	225	280	100	12.0	12	245	110	120	630	170



Current Rating (A)	Open Execution Cat. No.
2000A	COC2000
2500A	COC2500
3150A	COC3150

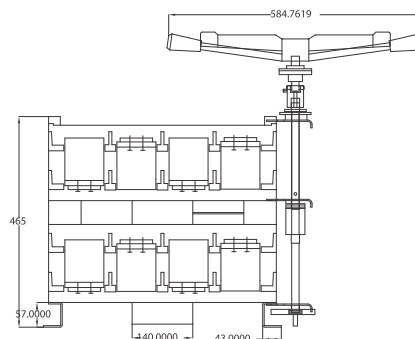
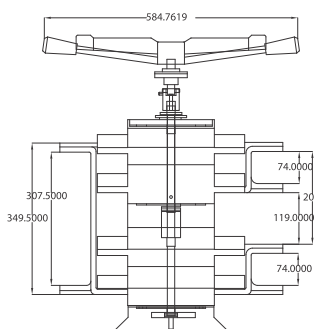
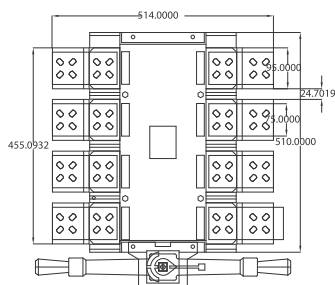

ALL DIMENSIONS ARE IN MM.

AMPS FRAME		OVER ALL DIMENSIONS				FEET HOLE					TERMINAL DIMENSIONS								
		TOTAL LENGTH	TOTAL WIDTH	TOTAL HEIGHT	COVER HEIGHT	A1	B1	E	F	G	H	TERMINAL WIDTH	TERMINAL THICKNESS	TERMINAL BOLTS	M	N	P	S	T
2000A	1	595	340	630	550	510	520	460	510	225	380	100	14.0	12	285	110	150	915	365
2500A	1	595	340	630	550	510	520	460	510	225	380	100	18.0	12	285	110	150	915	365
3150A	1	595	340	630	550	510	520	460	510	225	380	100	24.0	12	285	110	150	915	365

Product improvement is a continuous process. Above technical data is subject to be changed at any time owing to latest technological development.





MR. WATT

## ON LOAD CHANGEOVER SWITCHES

MR. WATT On Load Changeover Switch with thick steel sheet enclosure duly powder coated, are manually operated 4 pole switches having compact design for application in low voltage distribution circuits and motor circuits.

MR. WATT range of co-series, compact version On Load Changeover switches in thick steel sheet enclosure are manually front operated 4 pole switches with very compact design which helps to save the space in panel boards resulting in low costing of panel boards. These comprise of two On Load Switch

Range

Current range 40 Amp. to 3150 Amp. in Seven frame & thick Steel Sheet enclosure in Four Pole 415V



# ON LOAD CHANGEOVER SWITCHES



MR. WATT

## ON LOAD CHANGEOVER SWITCHES COMPACT VERSION WITH STEEL SHEET ENCLOSURE



400 Amps. Four Pole 415 V  
(Sheet Enclosure)

### RANGE & FRAME SIZE

Current range 40 A to 3150 A in seven frame sizes in Four Pole in Thick Steel Sheet Enclosure

SIZE 1	40A, 63A, 80A, 100A.
SIZE 2	125A, 160A, 200A.
SIZE 3	250A, 320A.
SIZE 4	400A, 630A.
SIZE 5	800A.
SIZE 6	1000A, 1250A, 1600A.
SIZE 7	2000A, 2500A, 3150A.

### SPECIFICATIONS

Rated Operating Voltage (V)	415
Rated Insulation Voltage (Ui)	1000 V
Rated Frequency (Hz)	50
Utilization Category	AC 23 A (63A-320A), AC 22 A (400A-3150A)
Rated impulse withstand Voltage (Uimp)	10 kV

### SALIENT FEATURES

- Enclosure is of fabricated thick steel sheet duly phosphated with seven tank process and with powder coated.
- Two earth connection points provided in enclosure.
- Strong and ergonomic operating handle with door interlock and padlock facility.
- Utilization category - AC 23A/ AC22A.
- Degree of protection IP -23.
- While breaking the circuit, guaranteed sufficient air sectioning clearance .
- Protection against over current and short circuit fault of high rupturing capacity upto 80 kA.
- Compact and standardized sizes for range 63A- 3150A - ideal for switch board manufacturers.
- Strong endurance and resistance to heat (Tropicalised ).
- Elegant & sleek in appearance.
- All current carrying parts are of special grade ETP copper and silver plated.
- Phase barriers provided between each phase terminal.
- Flag indicator for two stable positions ( I-O ) & possible switching, on or off, on load, thereby fulfilling the roll of switching device.
- The moulded body's raw material is Glass Fiber reinforced polyester (SMC) which has high mechanical and dielectric strength.
- Ample space for copper / aluminum cabling.



MR. WATT

# ON LOAD CHANGEOVER SWITCHES

## CONSTRUCTION

We have completed a range of On Load Changeover Switch in thick Steel Sheet Enclosure switches have been designed and developed indigenously to meet various needs of distribution circuits. Switches disconnected are manually controlled. They provide breaking or switching off on load and safety isolation.

The switching mechanism is quick make, quick break type independent of the speed of the operation. There are four breaks per pole, thereby resulting in faster quenching of arc. The load and line can be connected on either side by virtue of isolation on both sides. The entire switching mechanism along with the fixed and moving contact assembly are housed in a polyester-reinforced, moulded frame/cover, having high dielectric strength.



## CONTACT MECHANISM

The contact mechanism is knife blade type with self-cleaning action during operation. The fixed contact terminals in each phase have separate main and arcing contacts. The moving contact assembly has a four-set of contacts on a moving carrier, and each set of contacts is loaded with bouncing type strip springs which assist in the true movement during the making and breaking.

The moving contact mates with the fixed contact by a slide movement of the moving contact assembly. The contact is first made with the arcing contact and thereafter with the main contact. During breaking, the arc formation is across the arcing contacts, thereby protecting the main contacts, which results in enhanced life of the switch. The arc is effectively confined & quenched by the arc barrier in each phase.

The switches can be mounted inside a panel either in horizontal or vertical mode without any effect on the performance.



## OPERATING MECHANISM

The operating mechanism consists of a single/double side front-operated handle which drives the spring-assisted toggle mechanism, in turn operating the switch. There is a distinct indication of the position of the switch by way of a side-mounted flag indicator carrying the rotation O/I. In addition to position indication provided on the front of the switch, i.e. on the operating shaft.

In position 'I', supply I (Main) is connected to the load.

In position 'O', supply I is disconnected from the load.



# ON LOAD CHANGEOVER SWITCHES



**MR. WATT**



Current Rating (A)	Sheet Enclosure Cat. No.
40A	COC40
63A	COC63
80A	COC80
100A	COC100

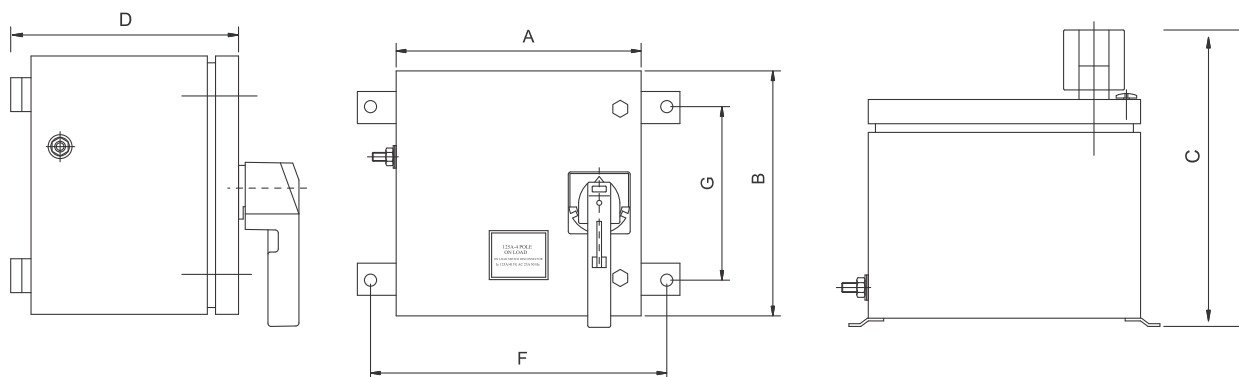

ALL DIMENSIONS ARE IN MM.

		A	B	C	D	F	G
40A	1	250	275	210	160	190	210
63A	1	250	275	210	160	190	210
80A	1	275	320	210	160	210	240
100A	1	275	320	210	160	210	240



Current Rating (A)	Sheet Enclosure Cat. No.
125A	COC125
160A	COC160
200A	COC200
250A	COC250
320A	COC320

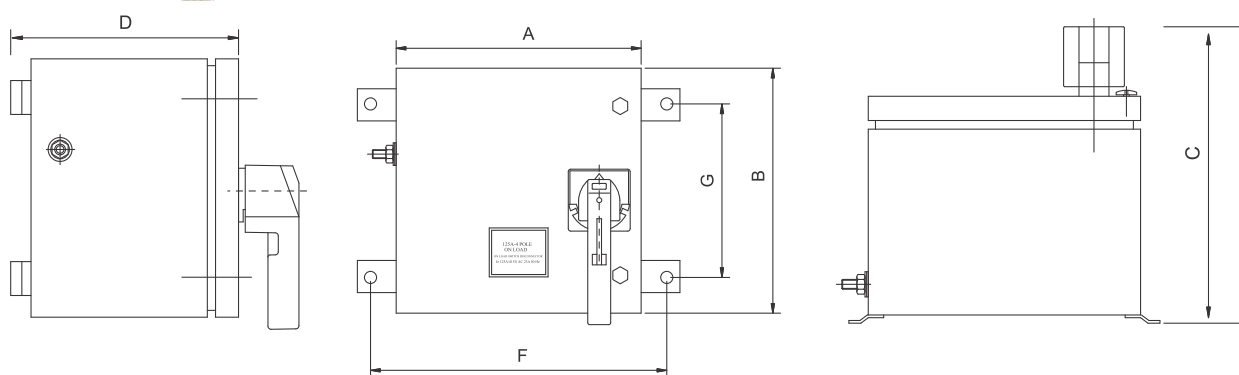

ALL DIMENSIONS ARE IN MM.

		A	B	C	D	F	G
125A	1	300	320	330	255	210	240
160A	1	300	330	340	265	210	240
200A	1	300	330	340	265	210	240
250A	1	375	420	350	270	400	300
320A	1	375	420	350	270	400	300

Product improvement is a continuous process. Above technical data is subject to be changed at any time owing to latest technological development.



**MR. WATT**



# ON LOAD CHANGEOVER SWITCHES

Current Rating (A)	Sheet Enclosure Cat. No.
400A	COC400
630A	COC630
800A	COC800

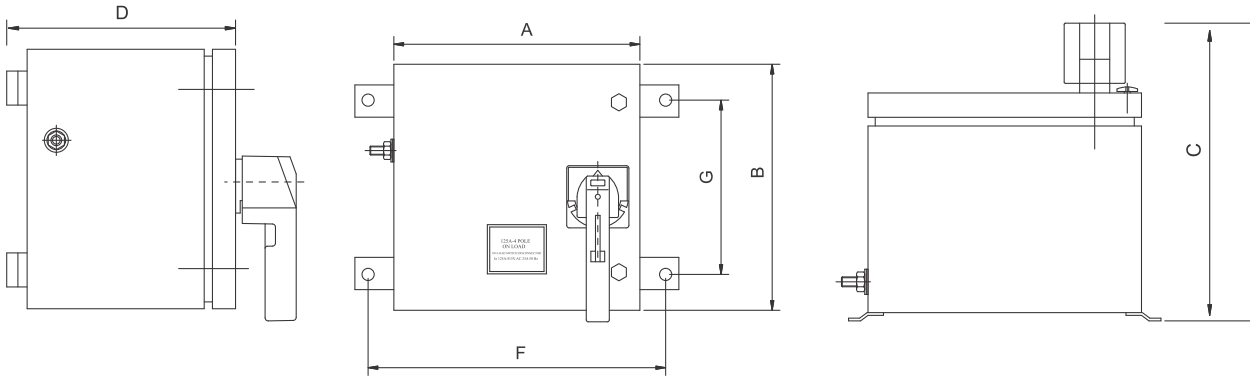

ALL DIMENSIONS ARE IN MM.

		A	B	C	D	F	G
400A	1	525	550	410	345	560	400
630A	1	525	550	410	345	560	400
800A	1	550	700	470	410	600	500



Current Rating (A)	Sheet Enclosure Cat. No.
1000A	COC1000
1250A	COC1250
1600A	COC1600
2000A	COC2000
2500A	COC2500
3150A	COC3150

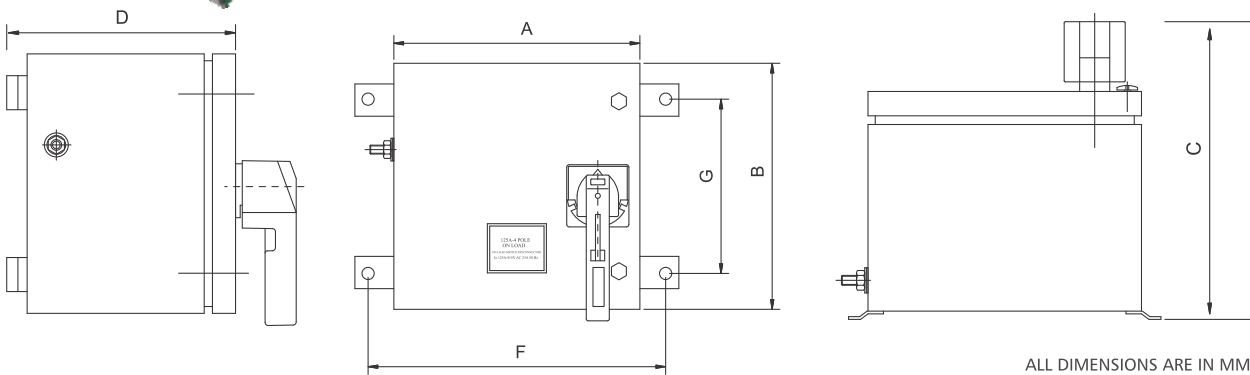

ALL DIMENSIONS ARE IN MM.

		A	B	C	D	F	G
1000A	1	700	700	470	410	760	550
1250A	1	700	700	470	410	760	550
1600A	1	700	700	470	410	760	550
2000A	1	700	850	680	590	760	700
2500A	1	700	850	680	590	760	700
3150A	1	700	850	680	590	760	700

Product improvement is a continuous process. Above technical data is subject to be changed at any time owing to latest technological development.



MR. WATT

MR. WATT Switch Fuse Changeovers are manually operated four pole switch with compact design for application in low voltage distribution circuits and motor circuits. These are used at places where continuity of supply is necessary which is maintained by switching to an alternate source of supply from main supply & supply is connected to load through the protection device as HRC Fuses in RYB Phases.

#### Range

Current range 63 Amp. to 630 Amp. in four frame sizes in Four Pole 415 V AC 50 Hz.

#### CONFORMITY TO STANDARDS

Conforms to IEC-60947- 1 & 3

IS/IEC - 60947- 3

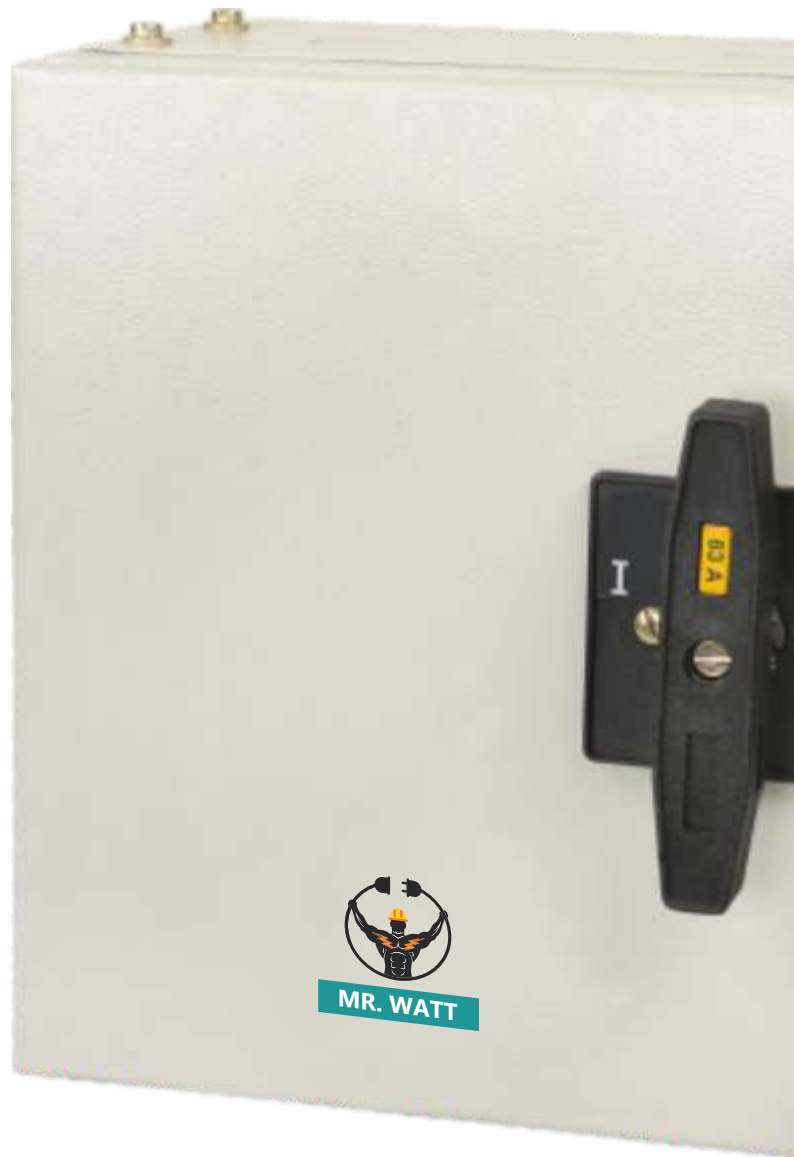





MR. WATT

## OFF LOAD CHANGEOVER SWITCHES

A comprehensive range of MR. WATT OFF LOAD Changeover Switches with side handle manual operation find wide application in all domestic as well as industries where individual system require safe and reliable transfer of power from main supply to alternate source of supply and vice versa. These are supplied in sheet enclosure with three stable positions

### RANGE

415 V AC 50 Hz

Type : CHU (U- type)

Rating : 16 Amp. & 32 Amp. 415V, 50Hz

Execution : DP, TP and Four Pole.

Type : Type CHK (Knief type)

Rating : 63 Amp. to 3150 Amp. 415V, 50Hz

Execution : DP, TP and Four Pole.

### CONFORMITY TO STANDARDS

Conforms to IEC - 60947-3

IS/IEC - 60947-3

### SPECIFICATIONS

Rated Operational Voltage (V) 240/415

Rated Insulation Voltage (Ui) 1000

Utilization Category AC 23 A

Rated impulse withstand Voltage 10 kV

(Uimp)

No. of Poles Double/Four  
Poles



32 Amps. Four Pole 415 V  
(U Type)



32 Amps. Double Pole 415 V  
(U Type)

# OFF LOAD CHANGEOVER SWITCHES



MR. WATT

## CONSTRUCTION (U - TYPE)

### Contacts

Contacts are made of electrolytic copper, Tin Plated for longer contact life / Increase of current carrying capacity and to ensure temperature rise within permissible limits.

### Operating Handle & Interlocking

The operating handle is made of steel and is provided on the right hand side of the switch enclosure. Door interlock ensures the door cannot be opened when the switch is in ON position thereby providing safety.

### Terminal Blocks

Terminal Blocks are made of Ceramic which has excellent thermal, mechanical and dielectric properties. Terminal Blocks are provided for cable termination.

### Enclosure

The enclosure is powder coated and made of sheet steel suitable for individual mounting. They are provided with adequate knockout for cable entry.



## SALIENT FEATURES

Conventional side handle operated switches suitable for individual mounting for OFF LOAD applications.

Quick make and Quick break mechanism.

Copper alloy used for moving current carrying parts with tin plated.

Totally enclosed fabricated thick steel sheet, dust proof, sleek enclosures with phosphate coating by seven tank system and powder coating for longer life.

Ample space for copper/aluminium cabling.

Door interlocking to prevent accidental opening of the changeover switch in "ON" position.

Switch Power from one source to the other source with reliability, safety and positively.

High class insulation provided. SMC & epoxy glass material used in high range of changeover switches.

Utilization category AC-22A, AC-23A with IP-23.



MR. WATT

# OFF LOAD CHANGEOVER SWITCHES

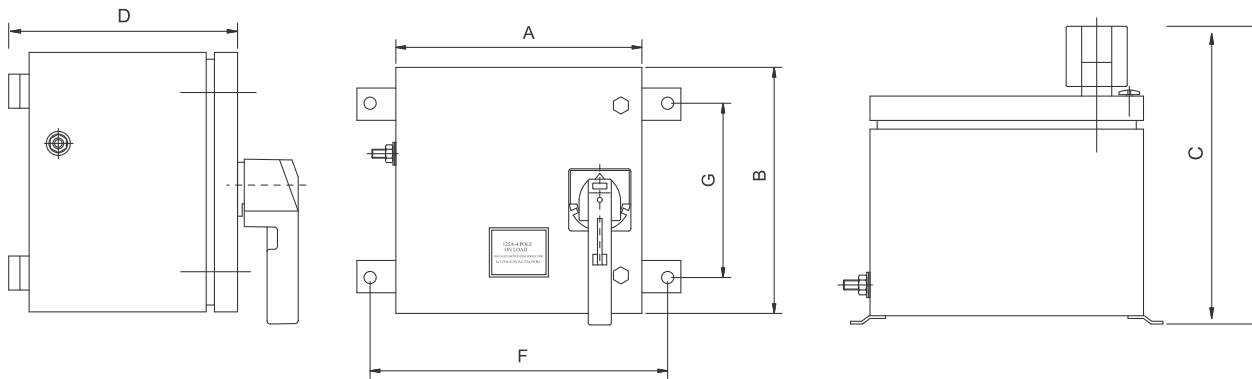

## CHANGE OVER SWITCHES DOUBLE POLE 415 V A. C.

RATING	A	B	C	D	E	F	G	Size of Cable Entry of Exite 1&1
16A	210A	137	92	155	73	177	170	19Ø
32A	235	150	92	183	80	182	175	25Ø
63A	322	203	213	259	137	280	355	38Ø
100A	385	203	233	308	137	303	355	38Ø
200A	430	292	260	304	320	508	355	248×61

## CHANGE OVER SWITCHES TRIPLE POLE 415 V A.C.

RATING	A	B	C	D	E	F	G	Size of Cable Entry of Exite 1&1
16A	210	172	92	155	98	210	175	19Ø
32A	235	204	92	183	214	234	175	25Ø
63	322	270	213	259	200	347	355	38Ø
100A	385	292	233	308	166	392	355	24867
200A	430A	330	260	304	357	413	405	397×88
320A	430	330	260	304	357	413	405	297×88

Product improvement is a continuous process. Above technical data is subject to be changed at any time owing to latest technological development.

# OFF LOAD CHANGEOVER SWITCHES



MR. WATT

## RANGE

Type	: Type CHK (Knief type)
Rating	: 63 Amp. to 3150 Amp. 415V, 50Hz
Execution	: DP, TP and Four Pole.
IEC	: 60947-3
Rating	: 63 Amp. to 3150 Amp. 415V, 50Hz
Utilization Category	: AC 22B



400 Amps. Four Pole 415 V  
(Knife Type)

## CONSTRUCTION (KNIFE - TYPE)

### Contacts (Moving/Fixed)

Moving Contacts are made of electrolytic copper, Tin Plated in shape knife blade type with self cleaning action during operation, The fixed contact terminals in each phase have separate main and arcing contacts for longer contact life / Increase of current carrying capacity and to ensure temperature rise with in permissible limits.

### Operating Handle & Interlocking

The operating handle is made of steel and is provided on the right hand side of the switch enclosure. Door interlock ensures the door cannot to be opened when the switch is in ON position thereby providing safety

### Terminal Blocks

Terminal Blocks are made of SMC/DMC which has excellent thermal, mechanical and dielectric properties. Terminal Blocks are provided for cable termination.

### Enclosure

The enclosure is powder coated which is made of sheet steel suitable for individual mounting. They are provided with adequate knockout for cable entry.

## SALIENT FEATURES

Conventional side handle operated switches suitable for individual mounting for OFF LOAD applications.

Quick make and Quick break mechanism.

Copper alloy used for moving current carrying parts with tin plated.

Totally enclosed fabricated thick steel sheet, dust proof, sleek enclosures with phosphate coating by seven tank system and powder coating for long life.

Ample space for copper/aluminium cabling.

Door interlocking to prevent accidental opening of the changeover switch in "ON" position.

Switch Power from one source to the other source with reliability, safety and positively.

Cable entry holes/slot covered with removable end plates are provided at the bottom and also at the rear side of the switch to facilitate cable connections from any side.

320 Amps. and above rating are provided with central back side connection provision.

High class insulation provided. SMC & epoxy glass material used in high range of changeover switches.

DMC / SMC terminal individual mould are provided for cable transmission having excellent mechanical thermal and dielectric properties.



MR. WATT

# OFF LOAD CHANGEOVER SWITCHES

## DIMENSION (KNIFE - TYPE)

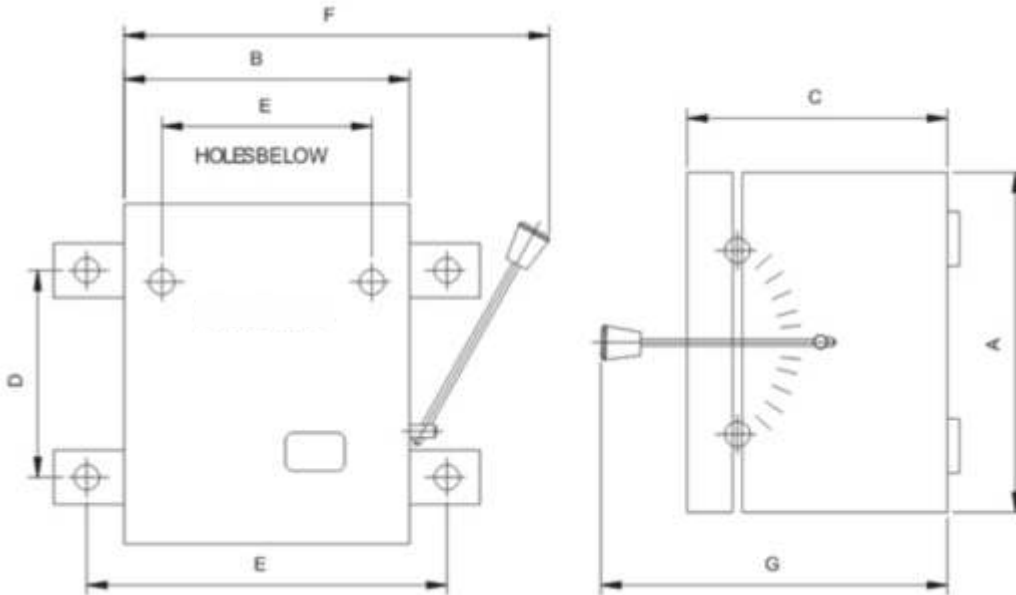

### CHANGE OVER SWITCHES DOUBLE POLE 415 V A. C.

RATING	A	B	C	D	E	F	G	Size of Cable Entry of Exite I&J
16A	210	229	92	155	150	267	170	19Ø
32A	235	260	92	183	165	300	175	25Ø
63A	322	311	213	256	137	388	355	38Ø
100A	385	380	233	308	171	480	385	248×67
200A	430	425	260	304	452	508	405	297×88
320A	460	457	320	300	497	550	515	410×100
400A	510	505	335	294	545	610	555	470×117
630A	584	584	390	351	620	710	610	540×133
800A	630	630	420	400	673	770	660	585×135
1000A	630	630	420	400	673	770	660	585×135
1250A	740	735	500	443	785	890	645	685×155
1600A	740	735	500	443	785	890	645	685×155
2000A	880	880	575	443	930	970	670	820×140

Product improvement is a continuous process. Above technical data is subject to be changed at any time owing to latest technological development.

# REWIREABLE SWITCH FUSE UNITS



MR. WATT

## RANGE

1) 16 Amps. & 32 Amps.

240V / 415V, 50Hz

In D.P., T.P. & T.P.N. in Deep Drawn Enclosure

2) 63 Amps. to 200 Amps.

240V / 415V, 50Hz

In D.P., T.P. & T.P.N. in Fabrication Enclosure

## CONFORMITY TO STANDARDS

Switch Fuse Units

Conforming to the latest IS/IEC : 60947 -3 with ISI marked.

## CONSTRUCTION

Switch Fuse units are fitted with sturdy side operating handle which drives the quick make-break mechanism incorporating operating springs. Liberal sized tin plated terminals, suitable for aluminium cable/bus-bar termination, are provided with terminal cover shields to prevent any accidental contact with live metal parts. Positive ON-OFF indication is provided on the switch door.

Switch Fuse units are fitted with sturdy side operating handle which drives the quick make-break mechanism incorporating operating springs. Liberal sized tin plated terminals, suitable for aluminium cable/bus-bar termination, are provided with terminal cover shields to prevent any accidental contact with live metal parts. Positive ON-OFF indication is provided on the switch door.

The enclosure is made of sheet steel, rust protected, phosphatized and powder coated. They are fitted with removable

## SALIENT FEATURES

- - Thick Steel sheet enclosure with rigorous anti rust conditioning with seven tank process to ensure smooth & lasting powder coated finish against corrosive atmosphere.
  - Suitable for surface mounting.
  - Provision of conduit knockouts and detachable gland plates.
  - Fully shrouded life parts.
  - All type contact are hard bright & tin plated for high conductivity & longer life.
  - Entry holes are provided at top & bottom and also at rear side to facilitate cable connection from any side.
- Quick make and break mechanism independent of the speed of operating handle with door interlocking.
- Terminal suitable for accommodating aluminium / copper conductors.







MR. WATT

# REWIREABLE SWITCH FUSE UNITS

## SWITCH FUSE UNITS WITH HRC

### RANGE

- 1) 63 Amps. to 200 Amps., 415 V, 50Hz  
415 V in T.P. & T.P.N. in Fabricated Enclosure

### CONFORMITY TO STANDARDS

Conforming to the latest IEC : 60947 1&3  
IS/IEC : 60947-3

### CONSTRUCTION

Fuse Switch units are fitted with sturdy side operating handle which drives the quick make-break mechanism incorporating operating springs. Liberal sized tin plated terminals, suitable for aluminium cable/bus-bar termination, are provided with terminal cover shields to prevent any accidental contact with live metal parts. Positive ON-OFF indication is provided on the switch door.

Contacts are made of electrolytic copper, electro-plated with silver, for better contact and greater resistance to corrosion. Specially designed female contacts ensure low contact resistance and better arc-control. Fuse switches are designed for use with HRC fuselinks conforming to IEC : 60269/IS : 13703.

The enclosure is made of sheet steel, rust protected, phosphatized and powder coated. They are fitted with removable top and bottom end plates provided with knock-outs for bus bars/cables entry. Front accessible door, fitted with dust-excluding gasket, is interlocked to prevent opening when the switch is in 'ON' condition. They are suitable for surface mounting.

### SALIENT FEATURES

- Tested for 80 kA as per utilization category AC-23 A.
- Thick Steel sheet enclosure with rigorous anti rust conditioning with seven tank process to ensure smooth & lasting powder coated finish against corrosive atmosphere.
- Degree of protection IP-23 and Utilization Category AC-23A.
- Suitable for surface mounting.
- Quick make and break mechanism independent of the speed of operating handle with door interlocking.
- Provision of conduit knockouts and detachable gland plates.
- Fully shrouded life parts.
- Rewireable fuse carriers can easily be replaced with fuse carriers to accommodate HBC fuse links.
- All type contact are hard bright & tin plated for high conductivity & longer type.
- Entry holes are provided at top & bottom and also at rear side to facilitate cable connection from any side.
- Terminal suitable for accommodating aluminium / copper conductors.

# REWIREABLE SWITCH FUSE UNITS



MR. WATT

## Dimensions

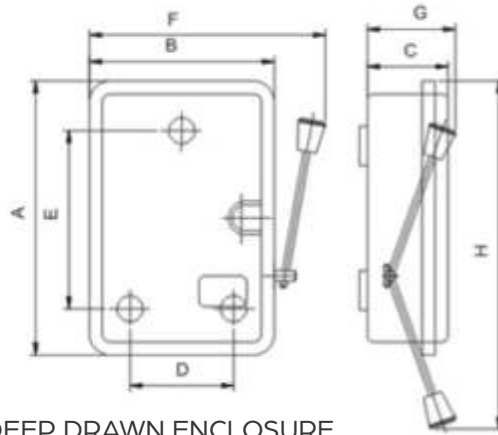

DEEP DRAWN ENCLOSURE

## SWITCH FUSE COMBINATION UNITS IN DEEP DRAWN ENCLOSURE

RATING	VOLTS	TYPE	REW	HRC	A	B	C	D	E	F	G	H
16A	240	SPN/DP	1216 N & C	*	144	102	62	62	102	122	67	157
16A	415	DP	1216 K	1216 KH	231	146	85	82	169	180	150	298
32A	240	SPN/DP	1232 N&K	*	231	146	85	82	169	180	150	298
32A	415	SPN/DP	1232 N & K	1232 KH	235	150	92	75	185	180	170	325

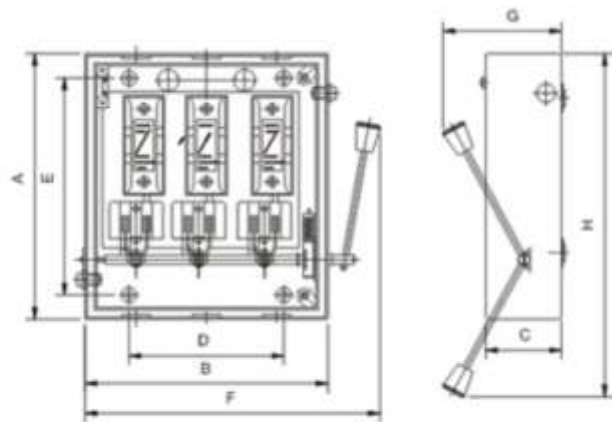

FABRICATION ENCLOSURE

## SWITCH FUSE COMBINATION UNITS IN FABRICATION ENCLOSURE

RATING	VOLTS	TYPE	REW	HRC	A	B	C	D	E	F	G	H
63A	415	DP	1563 K	1563KH	345	205	120	140	284	240	255	500
100A	415	SPN/DP	3100N&K	3100KH	450	237	155	165	390	280	280	585
200A	415	DP	--	3200KH	450	255	183	278	360	293	350	630



MR. WATT

# REWIREABLE SWITCH FUSE UNITS

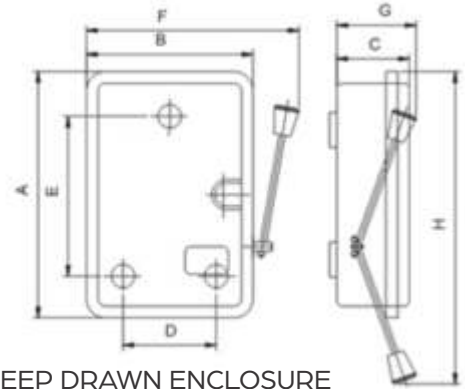

DEEP DRAWN ENCLOSURE

## SWITCH FUSE COMBINATION UNITS IN DEEP DRAWN ENCLOSURE

RATING	VOLTS	TYPE	REW	HRC	A	B	C	D	E	F	G	H
16A	415	TP & N	316 K	316 LH	230	180	85	85	169	210	150	310
32A	415	TP & N	332 K	332 KH	270	215	85	120	203	250	160	342

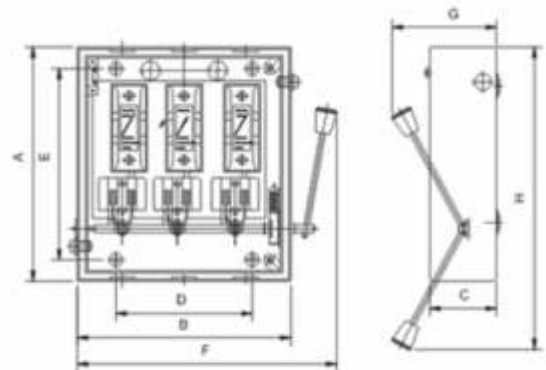

FABRICATION ENCLOSURE

## SWITCH FUSE COMBINATION UNITS IN FABRICATION ENCLOSURE

RATING	VOLTS	TYPE	REW	HRC	A	B	C	D	E	F	G	H
63A	415	TP & N	363K/KN	363KH	345	205	120	140	284	240	255	500
100A	415	TP & N	3100K/KN	3100KH	450	237	155	165	390	280	280	585
200A	415	TP & N	—	3200KH	450	255	183	278	360	293	350	630

Product improvement is a continuous process. Above technical data is subject to be changed at any time owing to latest technological development.

# REWIREABLE SWITCH FUSE UNITS

## KIT KAT TYPE FUSES

### SALIENT FEATURES

Ratings : 16A upto 500A

Rated voltage : 240V/ 415V

Rated Frequency : 50/ 60 Hz

Easy and quick to install

Low maintenance and replacement time

Cost-effective solution

EC grade copper is used for contacts for highest conductivity

Silver plating is done on the metal parts



MR. WATT



**L S Power Control Pvt Ltd**

C-440-443, Ansal Pioneer Park,  
Industrial Area, Bilaspur, Gurugram, India  
M.: 9810085244, 9810095244.